

M26.2/M30.2 T : 2 ruedas motrices
M26.4/M30.4 T : 4 ruedas motrices
M40.4/M50.4 T : 4 ruedas motrices



Capacidad de elevación

M26.2 / M26.4 T (500 mm)	2600 kg
M30.2 / M30.4 T (500 mm)	3000 kg
M40.4 T (500 mm)	4000 kg
M50.4 T (600 mm)	5000 kg



Altura de elevación estándar.....3,70 m



Neumáticos

M26 / M30 T	16,5/85-24 SGI 8 PR
M40.4 / M50.4 T	18 R 22,5 XF TUBELESS
traseros:	
M26.2 T	9.00-16 EM5 10 PR
M30.2 T	10 R17.5 XZT
M26.4 / M30.4 T	10.5 - 80 R18 TG 42 10PR
M40.4 / M50.4 T	340/80 R18



Horquillas (mm)

Longitud	1200
Anchura x espesor	
M26 / M30 T	125x40
M 40.4 T	150x50
M 50.4 T	150x60



Frenos hidráulicos multidiscos con baño de aceite



Motor PERKINS Euro III (Tier 3/Stage III A)

Tipo	1104 D 44 T
Cilindrada	4 cyl. - 4400 cm ³
Régimen nominal	2200 rpm
Potencia (ISO/TR 14396)	70kW (95 cv)
Par máx	392 Nm a 1400 rpm
Inyección directa	
Refrigeración por agua	
Paso de cuesta a vacío/en carga	
M26-2 / M30-2 T	29%/45%
M26-4 / M30-4 T	70%/75%
M40-4 / M50-4 T	80%/80%



Transmisión

Convertidor de par
 Inversor de marcha.....electro-hidráulico
 4 velocidades delantera y trasera
 Velocidad de desplazamiento máx.*

.....	24 km/h
Bloqueo de diferencial hidráulico M26.2 / M30.2 T	
Mando de cambio 4/2 ruedas motrices electro-hidráulico	
M26.4 / M30.4 / M40.4 / M50.4 T	



Hidráulica

Bomba principal de engranajes:.....	Presión/caudal
M 26.2 T / M 26.4 T	185 bar/89 l./mn
M 30.2 T / M 30.4 T	185 bar/89 l./mn
M 40.4 T / M 50.4 T	210 bar/89 l./mn
Divisor de caudal prioritario Load sensing	
Para la dirección	145 bar/89 l/min
Nivel sonoro en el puesto de conducción (Segun 12053)	
M26/30	72 dB
M40/50	76 dB



Capacidades

Sistema de refrigeración	13 l
Aceite motor	8,5 l
Aceite hidráulico	64 l
Aceite transmisión.....	15,5 l
Carburante	85 l



Peso (con mástil estándar y horquillas)

M26.2 T	5800 kg
M30.2 T	6100 kg
M26.4 T	5880 kg
M30.4 T	6180 kg
M40.4 T	6700 kg
M50.4 T	7660 kg
M50.4 T	7660 kg

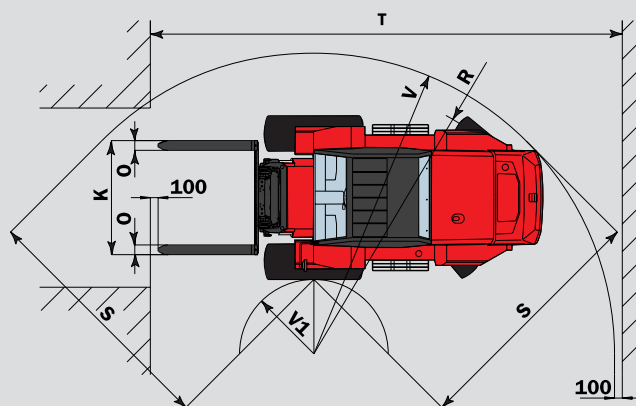
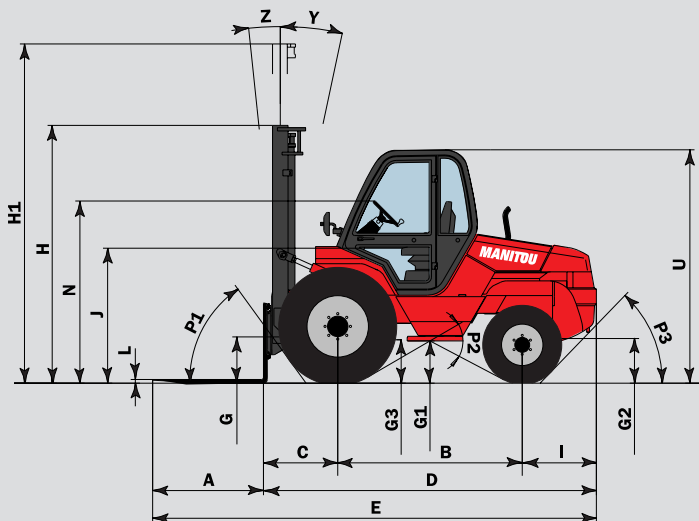

	Mástil de rodillos		
	M26.2 M30.2	M26.4 M30.4	M40.4 M50.4
A	1200	1200	1200
B	2000	2080	2124
C	810	810	762
D	3635	3635	3745
E	4835	4835	4945
F	1670	1670	1620
F1	1520	1760	1720
G	495	495	265
G1	465	395	375
G2	420	290	310
G3	480	480	360
H	2785	2785	2910
H1	4815	4815	4815
I	825	745	855
J	1480	1480	1435
K	1470	1470	1670
L	40	40	50
N	1960	1960	1925
O	125	125	150
P1	54°	54°	43,5°
P2	58°	57,5°	50°
P3	46°	56,5°	48,5°
R	3730	3930	3985
S	3215	3115	3366
T	6140	6280	6327
U	2540	2540	2495
V	3930	4070	4155
V1	1015	1350	1120
W	2105	2105	2080
Y	12°	12°	15°
Z	6°	6°	15°

